

END SECTIONS FOR ROUND PIPE

Dia.	Gauge	Weight	* A	* B	* H	* L	* W	Slope	Overall Width
6"	18	10	4	1	3	8	12	2	20"
8"	18	14	5 3/4	5	4	14 1/2	16	2 1/4	27 1/2"
10"	18	17	7 5/8	6	6	14 1/2	20	2 1/2	35 1/4"
12"	16	25	7	6	6	21	24	2 1/2	38"
15"	16	33	8	8	6	26	30	2 1/2	46"
18"	16	42	8	10	6	31	36	2 1/2	52"
21"	16	49	9	12	6	36	42	2 1/2	60"
24"	16	65	10	13	6	41	48	2 1/2	68"
30"	14	123	12	16	8	51	60	2 1/2	84"
36"	14	184	14	19	9	60	72	2 1/2	100"
42"	12	320	16	22	11	69	84	2 1/2	116"
48"	12	375	18	27	12	78	90	2 1/4	126"
54"	12	440	18	30	12	84	102	2 1/4	138"
60"	12/10	610	18	33	12	87	114	2	150"
66"	12/10	697	18	36	12	87	120	2	156"
72"	12/10	720	18	39	12	87	126	2	162"
78"	12/10	810	18	42	12	87	132	1 1/2	168"
84"	12/10	850	18	45	12	87	138	1 1/2	174"
90"	12/10	910	24	37	12	87	144	1 1/2	192"
96"	12/10	985	25	35	12	87	150	1 1/2	200"

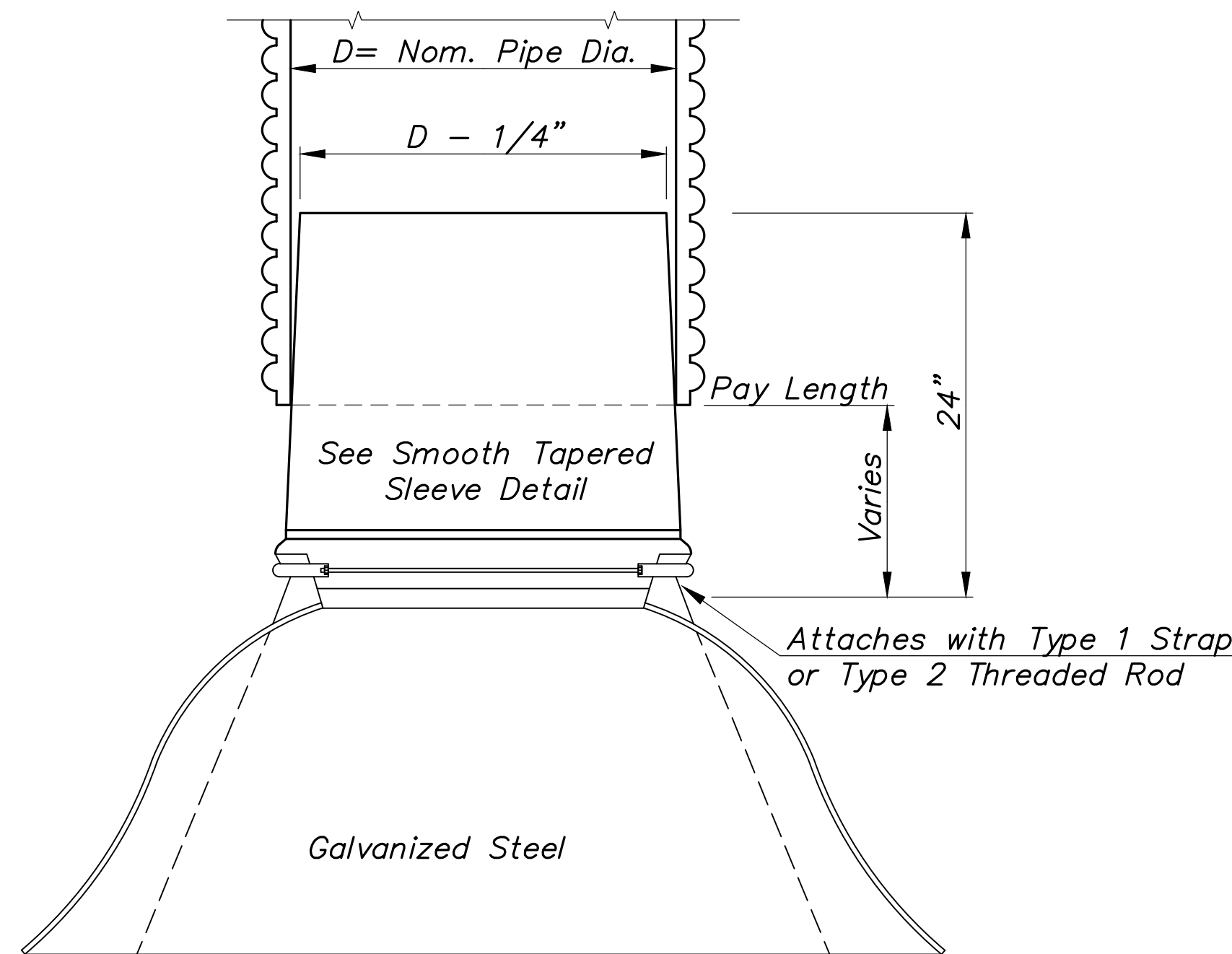

TAPERED SLEEVE FOR ATTACHING STEEL END SECTIONS TO SMOOTH PIPE

GENERAL NOTES

Toe plate extensions where specified, to be punched to match holes in apron lip. 3/8" bolts to be furnished. The length of toe plate to be as follows:

- W + 10" for 12" to 30" diameter pipes inclusive.
- W + 20" for 36" to 60" diameter pipes inclusive.
- W + 10" for pipes arches with rise of 13" to 29" inclusive.
- W + 20" for pipes arches with rise of 33" to 75" inclusive.

Multiple panel end sections shall have lap seams which are to be tightly jointed by bolts. Corner plate, and toe plate to be same gauge as end section.

For 60" and larger diameter pipe end sections, reinforced edges to be supplemented with hot dipped galvanized stiffener angles.

For 77"x 52" and larger pipe arch end sections, reinforced edges and center panel seams to be supplemented by hot dipped galvanized stiffener angles.

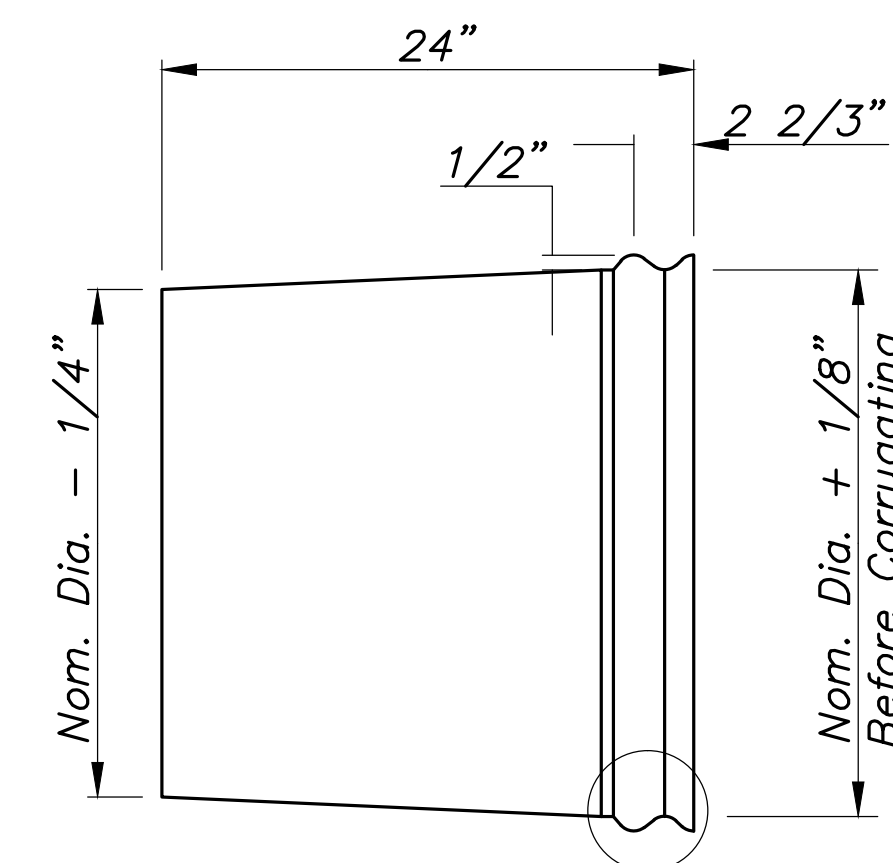

Form 1/2"x 2 2/3" Corrugations. Maintain Inside Diameter of Sleeve.

SMOOTH TAPERED SLEEVE DETAIL

NOTE: Metal to be 12 Gage Smooth Galvanized in Accordance with AASHTO M218.

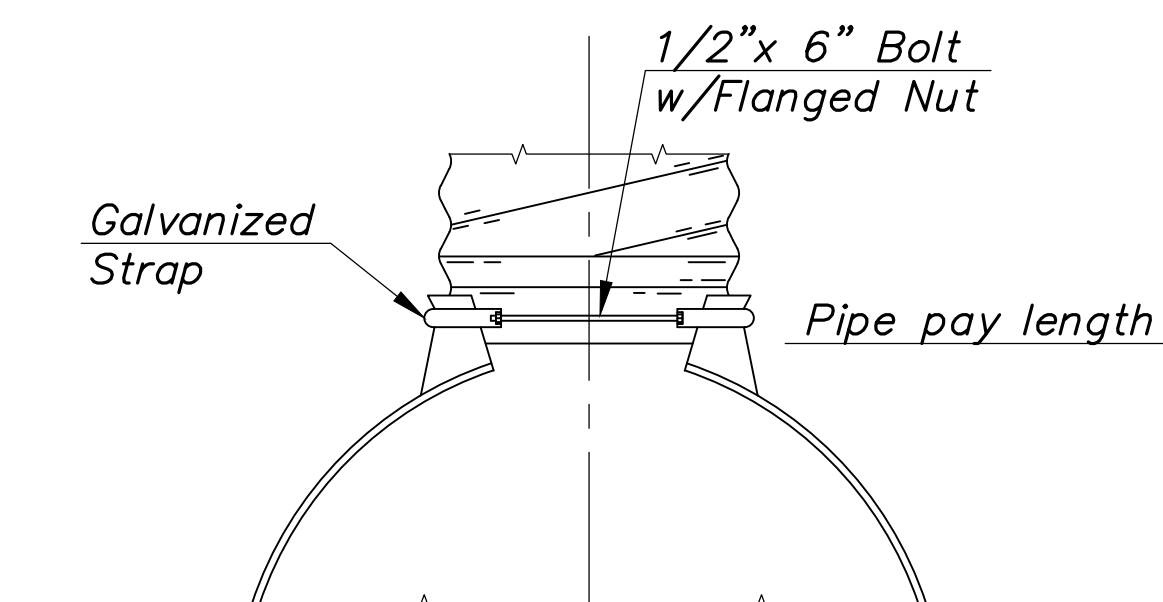

TYPE 1

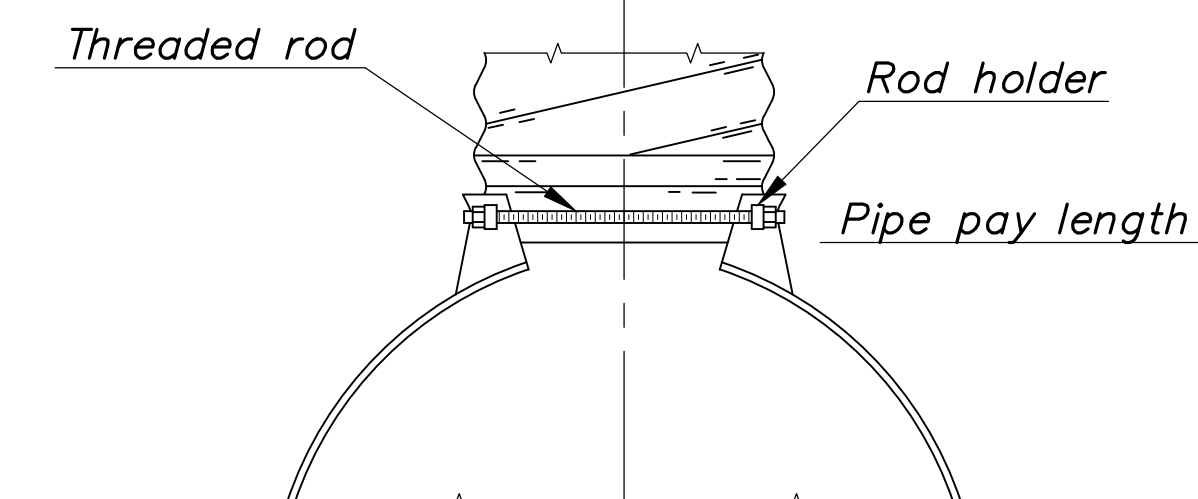

TYPE 2 CONNECTIONS

END SECTIONS FOR ARCHED PIPE

Span & Rise	Round Equivalent	Gauge	Weight	* A	* B	* H	* L	* W	Slope	Overall Width
17x13	15"	16	25	7	9	6	19	30	2 1/2	44"
21x15	18"	16	32	7	10	6	23	36	2 1/2	50"
24x18	21"	16	42	8	12	6	28	42	2 1/2	58"
28x20	24"	16	52	9	14	6	32	48	2 1/2	66"
35x24	30"	14	92	10	16	8	39	60	2 1/2	80"
42x29	36"	14	133	12	18	9	46	75	2 1/2	99"
49x33	42"	12	233	13	21	12	53	85	2 1/2	111"
57x38	48"	12	315	18	26	12	63	90	2 1/2	126"
53x41	48"	12	330	18	25	12	63	90	2 1/2	126"
64x43	54"	12	357	18	30	12	70	102	2	138"
60x46	54"	12	375	18	34	12	70	102	2	138"
71x47	60"	12/10	480	18	33	12	77	114	1 1/2	150"
66x51	60"	12/10	487	18	33	12	77	116	1 1/2	152"
77x52	66"	12/10	616	18	36	12	77	126	1 1/2	162"
73x55	66"	12/10	625	18	36	12	77	126	1 1/2	162"
83x57	72"	12/10	670	18	39	12	77	138	1 1/2	174"
81x59	72"	12/10	680	18	39	12	77	138	1 1/2	174"
87x63	78"	12/10	729	20	38	12	77	148	1 1/2	192"
95x67	84"	12/10	755	20	34	12	87	162	1 1/2	206"
103x71	90"	12/10	810	20	38	12	87	174	1 1/2	216"
112x75	96"	12/10	907	20	40	12	87	174	1 1/2	222"

* - Dimensions in Inches Plus or Minus Standard Shop Tolerance.

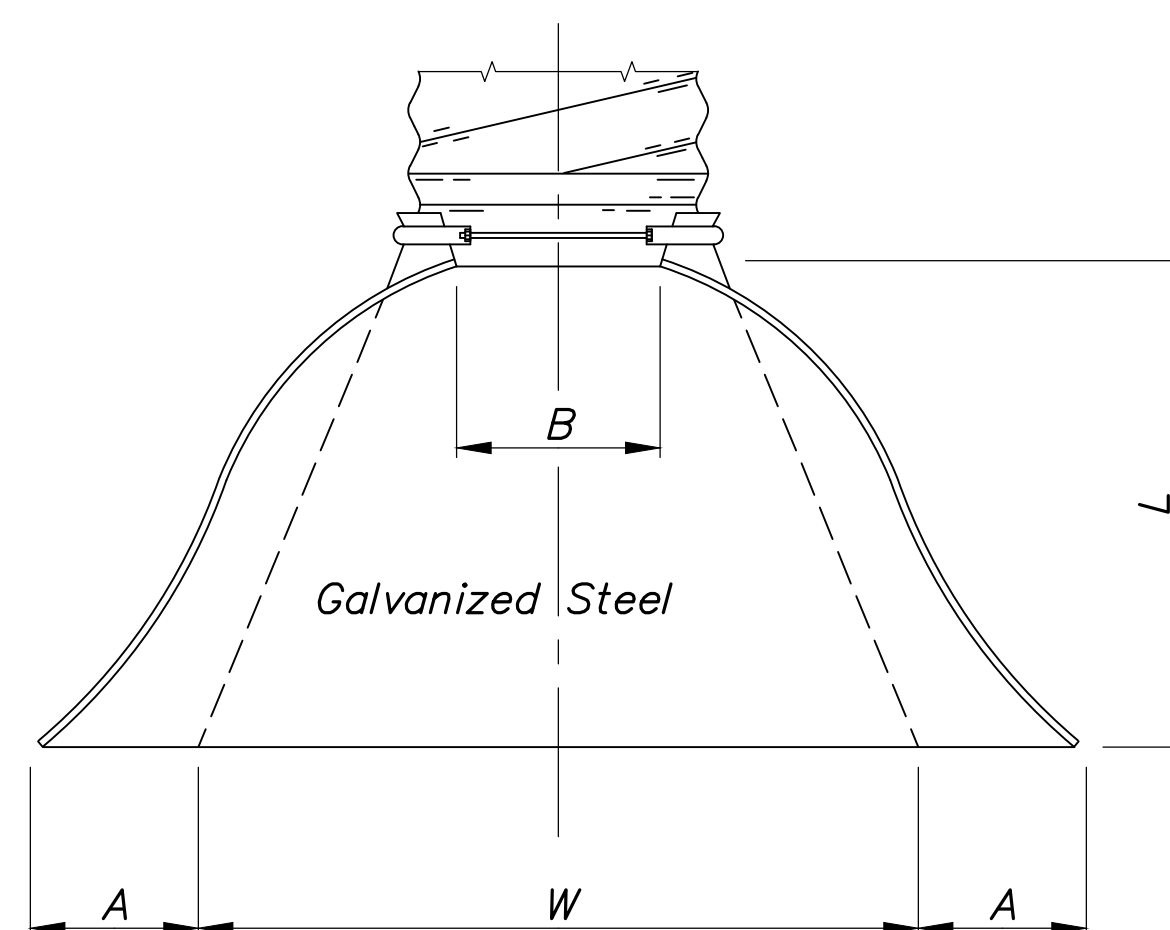

PLAN

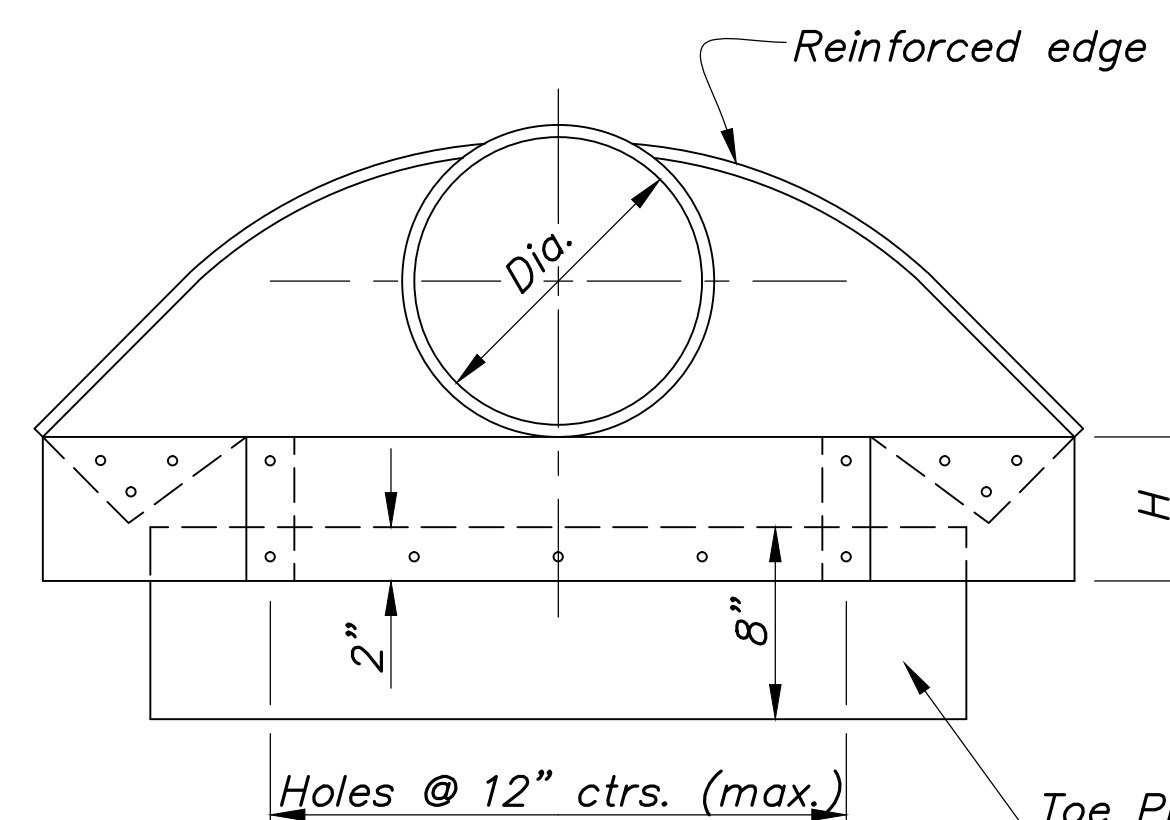

FRONT

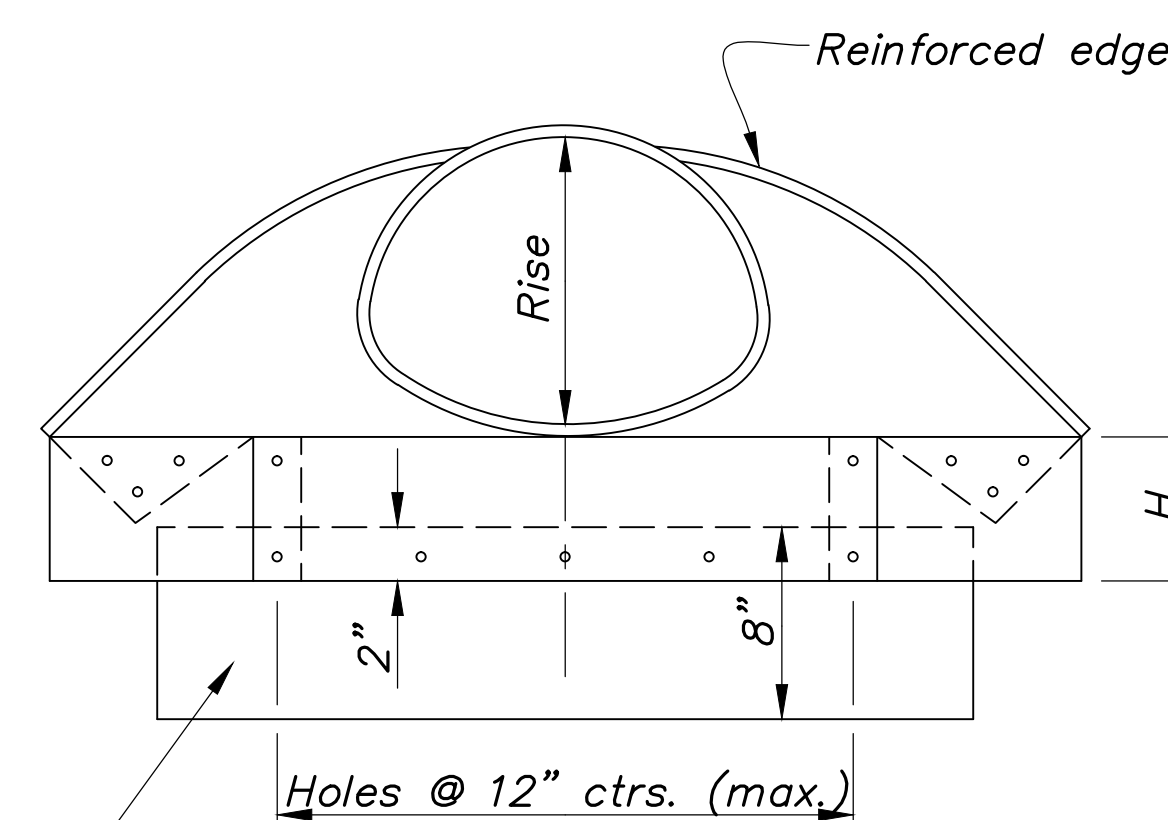

FRONT

No.	Date	Revisions

STANDARD END SECTION FOR ROUND & ARCHED PIPES